



Only 1 person required for operation

Electrically powered

Radio remotely controlled

Extremely compact

Loads and unloads the nose gear automatically

Park your aircraft using the last corner of your hangar and save space

MRO/FBO



PUSHBACK



MILITARY



HELICOPTER



AVION REVUE
Excellence Award 2019
Handling of the Year

Increase your efficiency significantly.

The safest and most effective way of moving aircraft towbarless. Electrify your Ground Handling.





Mototok.
The difference to any other tug system:
Flexibility, safety, cost savings –
at the highest innovative level.



A big idea in a small format. Name: Mototok. Distinguishing features: Fully electric drive. Revolutionary in its simplicity. Extremely compact. Uniquely flexible. And very high performance. With the remote control feature of the Mototok, the operator is able to move anywhere around the aircraft to see every vantage point. The operators eyes never leave the aircraft while it is in movement.

Mototok – Introduction	2
Take a look inside	4
The top Advantages of using a Mototok tug	6
A Comparison between Towing Principles	8
Mototok for Hangar Operations	12
Mototok for Pushback	14
I-OPS – Intelligent Oversteering Protection System	18
Ground Handling goes digital	20
AGV – Autonomous Driving	22
Mototok Spacer 250 / 400 – for Wide and Narrow Bodies	24
Mototok Spacer 8600 Pushback – for Narrow Bodies and Regional Jets	26
Mototok Spacer 8600 MRO/FBO – for Narrow Bodies and Regional Jets	28
Mototok TWIN Series – for Regional Aircraft and Business jets	30
Mototok LB Series – for air forces	32
Mototok TWIN Wide – for transport aircraft	34
Mototok ALLIGATOR 4000 Superflat	36
Mototok M Series – for Business Jets and Small Aircraft	38
Mototok Helimo – for Helicopter with Skids	40
German Art of Engineering	42
Our Customers	44
Technical Data	46

A wide range of types are available: Our biggest Mototok model so far – the Spacer 250 – excels with a towing capacity of 250 tonnes. Another model with a capacity of 400 tons is planned. The first tests are scheduled for the 2nd half of 2020. Our Model Spacer 8600 has a NTO licence for pushing back Boeing 737, Airbus A320 and families.

The TWIN model is suitable for regional and business jets. And our smallest model M fits under almost every small aircraft. Mototok also has specialists in its portfolio: extremely flat, extremely wide or for helicopters with landing skids.

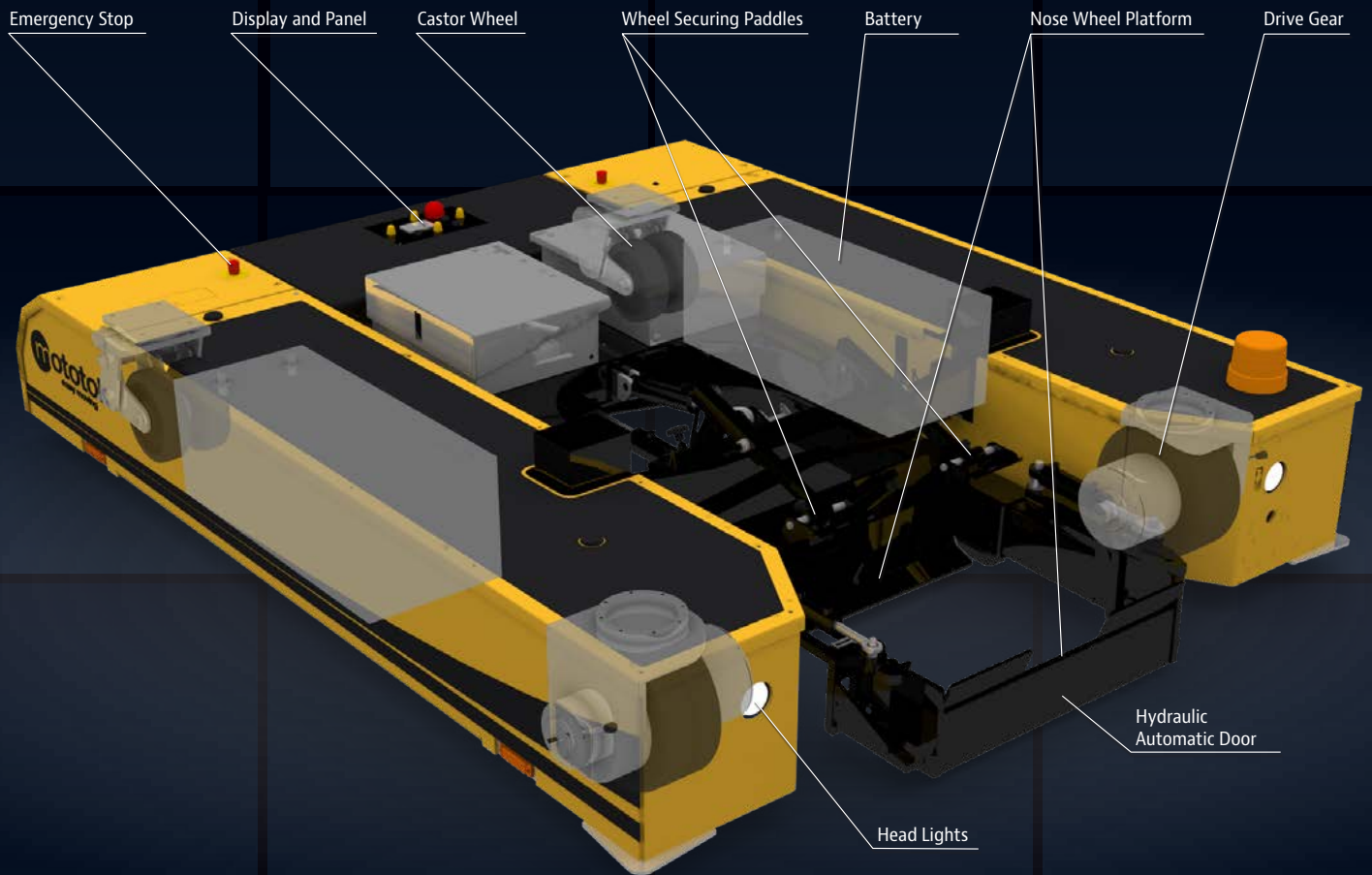

Take a look inside.

Extremely powerful electric motors driven by high-performance, maintenance-free batteries with high cycling capability provide enormous driving forces. Extremely high initial torque ensures smooth acceleration, particularly at the start. The charging capacity is sufficient for lots of operations.

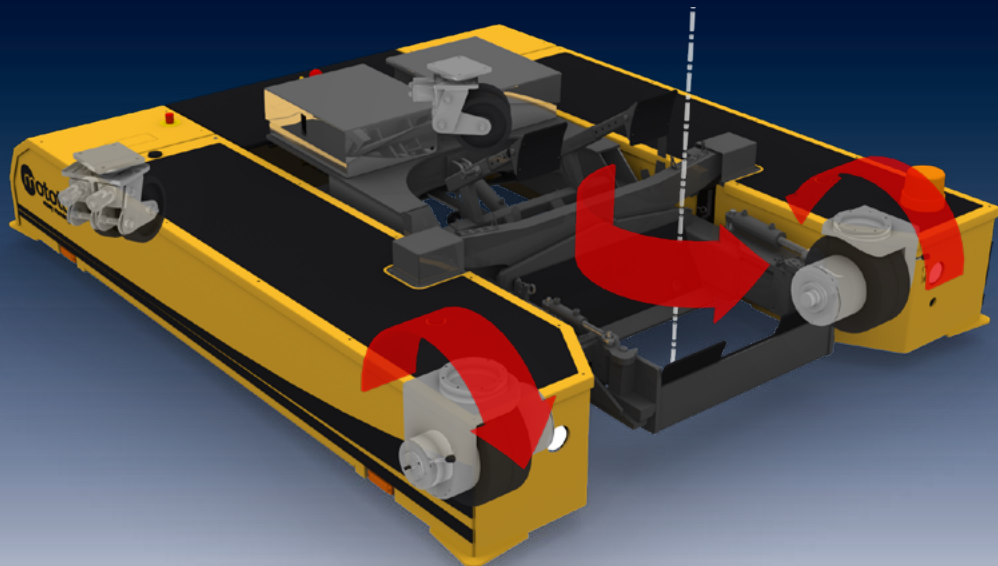



Turning on the spot with no wingtip movement: The Mototok Principle.

Mototok is intelligent. The steering of a Mototok is performed through different rotating speed of both processor-controlled wheel-hub motors. A perfect turn on the spot is naturally no problem: one motor rotates forwards, the other backwards and carry out a precise turning manoeuvre. The aircraft remains almost immovable from its location during the turn. Accidents through collisions are practically out of the question. In addition, no transverse forces are exerted on the nose gear, so that no damage is caused to the bearings and other gear-related components. According to the relative rotation speed of both driving wheels every route can be performed.

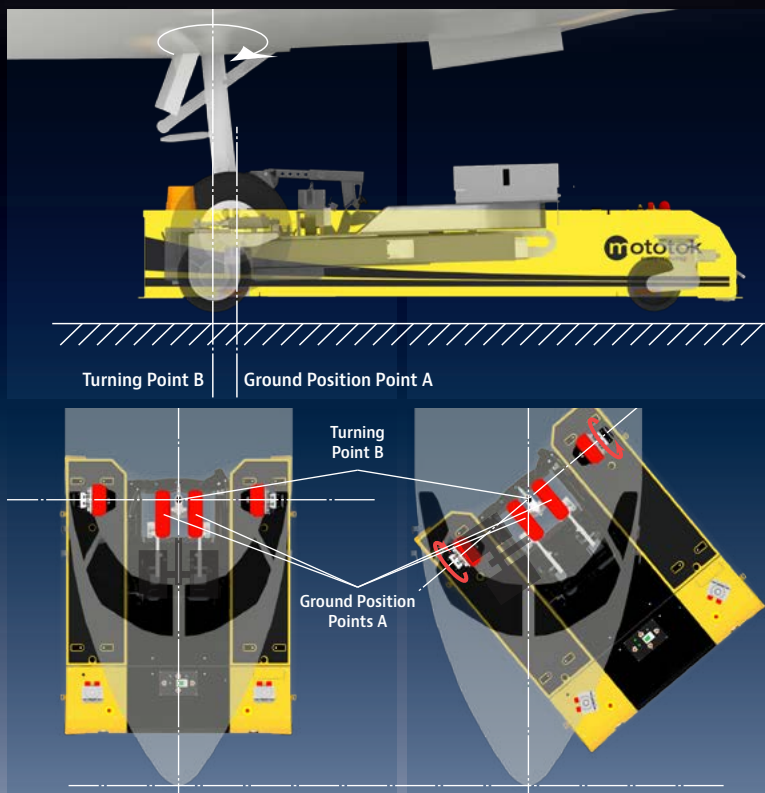

The top advantages of using a Mototok tug.



Towing with a conventional Tractor:
At least 4 Persons needed

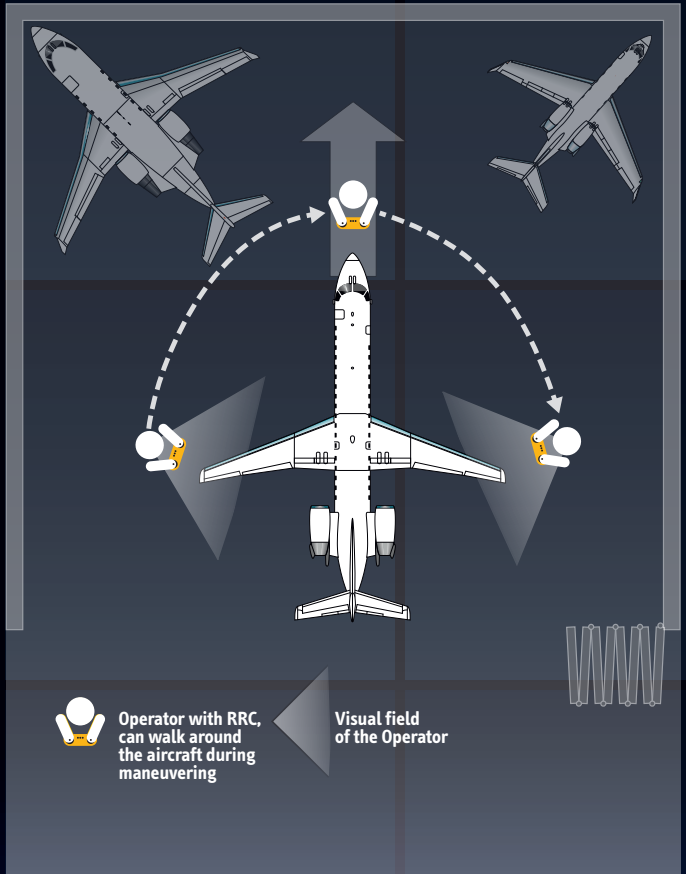

Circumferential view – only one person with a radio remote control (RRC) needed for moving the aircraft

- ⊕ Industrial radio remote control. The operator is able to walk around the aircraft during maneuvering – he is essentially his own "wing-walker"
- ⊕ "Hands free" connection to the nose gear. Engaging and disengaging is done automatically in seconds by a tap on the remote.
- ⊕ No exit or entry path to consider for engaging and disengaging of the nose gear. Park your aircraft where you want – closely against a wall or in the hangar's corner
- ⊕ Low maintenance costs. No bulky diesel engine – clean electric drive.
- ⊕ Uniquely designed and microprocessor controlled.

Cost effective.

- Low personnel costs by means of wireless remote control – the operator is essentially a “wing walker” himself
- Increases the number of aircraft in your Hangar
- No driving licence required
- Extremely low maintenance costs, no maintenance plan necessary

Flexible.

- Manoeuvre a wide range of aircraft with the same Mototok-model – ONE MACHINE for all corporate aircraft single or double nose wheel including helicopters
- Connect the aircraft from the front or the rear
- Hydraulic nose wheel adjustment * – for different nose wheel diameters

Safe.

- Hydraulic fixation of the nose wheel
- Fully programmable speeds, braking curves, initial torques and over steering protection *
- Gentle treatment of the landing gear with a built in hydro-pneumatic clamping system
- 100 % circumferential visual control around the aircraft. No knocks. No collisions. Optimum use of limited space!

* Available on some Mototok models only

Easy-to-use.

Docking takes a matter of seconds from the rear or front of the nose wheel. Simply drive the Mototok up to the nose wheel. The wheel is then hydraulically fixed firmly in position and raised – ready for take off! All this with no awkward strap, no inconvenient winch. No bolts or tools are required.

- Radio remote controlled operating under an industrial frequency code approved for airports.
- Automatic connection to the aircraft’s nose wheel with one click.
- No straps, no winch, no tools required.



Automatic One-Click Loading.

As simple as pressing a button:

1. The door closes hydraulically
2. The platform lifts up
3. The securing paddles clamp the nose wheel gently

Why is Mototok the best tug system in the market?

A comparison between towing principles.

Conventional tow tractor with a tow bar

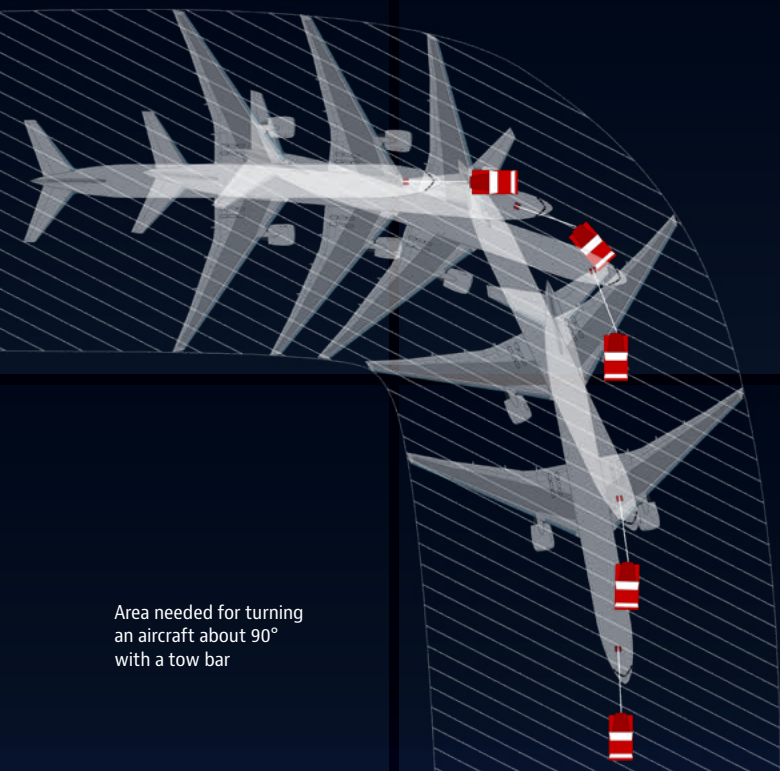

Maneuvering with a towbar means “steering by moving”. Turning the nose gear and moving the aircraft are two inseparable motions when using a tow bar. Turning the nose wheel is only possible when the aircraft is moved backwards or forwards. The aircraft has to be moved several meters for the nose gear to turn and move the aircraft into another direction. This in turn increases the space required for manoeuvres.

- ⊖ **Many different tow bars** have to be stored for different types of aircraft.
- ⊖ **High risk of accidents and damage** of the aircraft.
- ⊖ At least **one second person necessary as a wing-walker** due to the minimized view of the operator.
- ⊖ **High maintenance level** due to combustion engine.

Other towbarless tugs

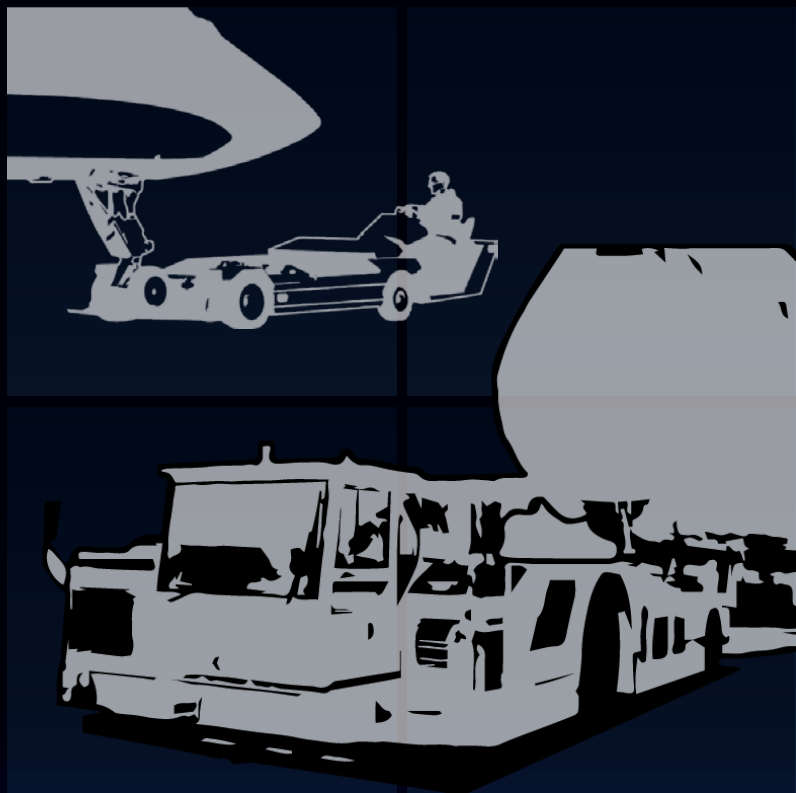

This principle means also “steering by moving”. The space requirement is approximately the same as with using a tow bar.

- ⊖ **Winches and straps** for fixation often needed.
- ⊖ At least **one second person necessary as a wing-walker** due to the minimized view of the operator.
- ⊖ The vehicles have **large dimensions** and **require a lot of parking space**.

Best Choice!

Tugs with a rotary table

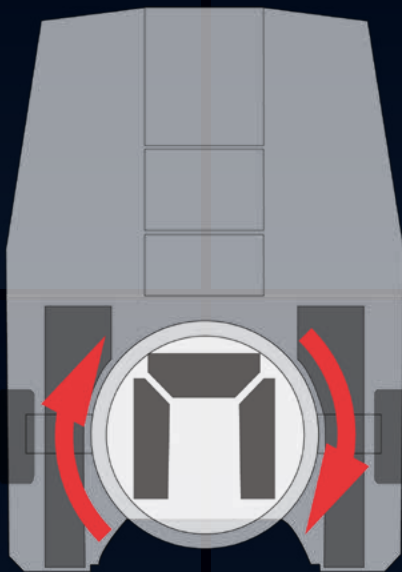

The nose landing gear is clamped on a rotating turntable to prevent damage to the nose wheel if the maximum turning angle of the nose wheel is reached. The aircraft tractor can continue to turn, but the turntable remains stationary.

- Can load the aircraft **only from the side** of the aircraft.
- The **Oversteering Protection System** only **works reliably** when **pulling** the aircraft. When pushing, the turntable behaves in a similar way to the castor on a shopping trolley due to the nose wheel's overrun: the wheel turns. This can only be prevented by manually fixing the turntable by the operator. **But this deactivates the oversteering protection function.**
- **No automatic fixation of the nose gear:** there is no possibility of bringing **hydraulic** or **electrical lines** into the **rotating platform** without risking a timely defect.
- **Safety issue:** Due to the large and unfavourably placed drive wheels, there is a **danger of crushing** the operators feet during manoeuvring

Moving an aircraft the innovative way – with Mototok!

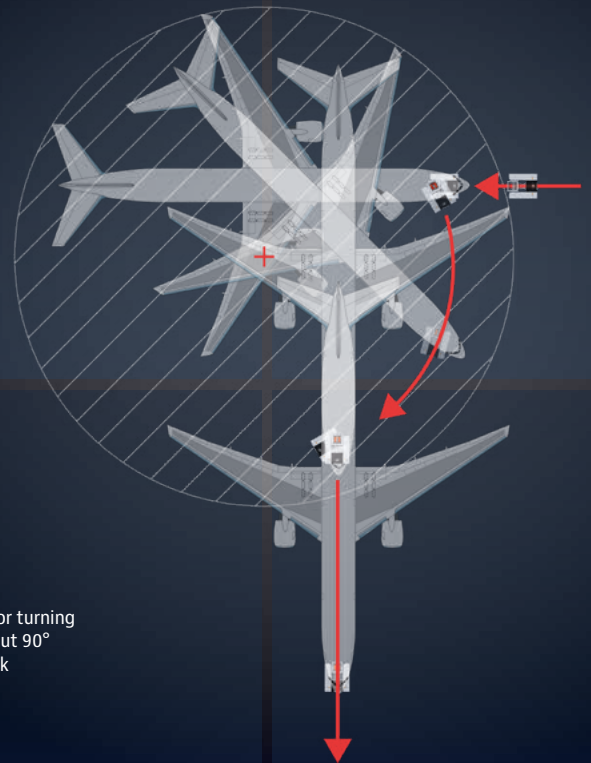

Area needed for turning an aircraft about 90° with a Mototok

Manoeuvring with Mototok is the easiest and safest by far. With Mototok, both turning the nose gear and moving the aircraft are two completely different movements. The fuselage and wingtips remain in position whilst turning the nose gear. The result is a minimum requirement of space. This example shows that turning an aircraft by 90° reduces manoeuvring space to a circle.

- + **Best overall sight** thanks to remote controlled maneuverings.
- + **No winches, no straps:** Convenient and quick automatic nose gear loading.
- + **Low maintenance** thanks to full electric drive.
- + **Lowest space requirement** when pushing or pulling the aircraft.
- + **Safe** thanks to **oversteering protection** on many models.



"Our Mototok is the second best piece of equipment in the hangar (the airplane is first)!"

"The ease of operation and the ability for one person to safely manoeuvre our plane in and out of our hangar because of the industrial remote control wing walker feature is unbeatable. This is a quality machine, very reliable."

Steve Nelson, Aviation Manager & Chief Pilot,
TLS Aviation LLC



Top: The view outside a standard tug – the operator needs at least two additional wing walkers.

Middle: Working with conventional tugs

Bottom: Using tow bars or other towbarless systems means cumbersome handling

Moving an aircraft the innovative way – with Mototok: Circumferential view around the aircraft, easy and convenient handling. Mototok makes the use and storage of different tow bars unnecessary. And it needs far less space than conventional tractors.



**Mototok for Hangar Operations:
Only Mototok generates up to
60% more space in your hangar.**



Mototok excels in tight situations: Park your aircraft safely, easily and effectively where you want: In the hangars corner, directly towards the hangars wall or near by other aircraft in the hangar. Save space in the process – depending on your hangar situation up to 40%.

Operating with normal tugs with or without a towbar is intricate. Turning the nose wheel whilst maneuvering without moving the aircraft is impossible. Additionally the operator has to consider the exit path of the tug. Thus, parking the aircraft with old technology is unprofitable. You are not able to use your hangars full capacity.

The low height, the compact design and the radio remote control of mototok tugs gives you the fully control of the hangars space. It saves costs through optimized use of limited space.

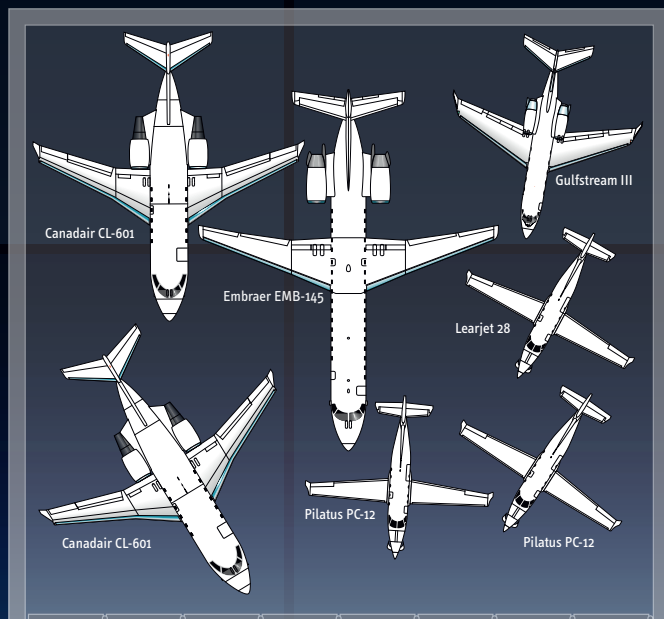
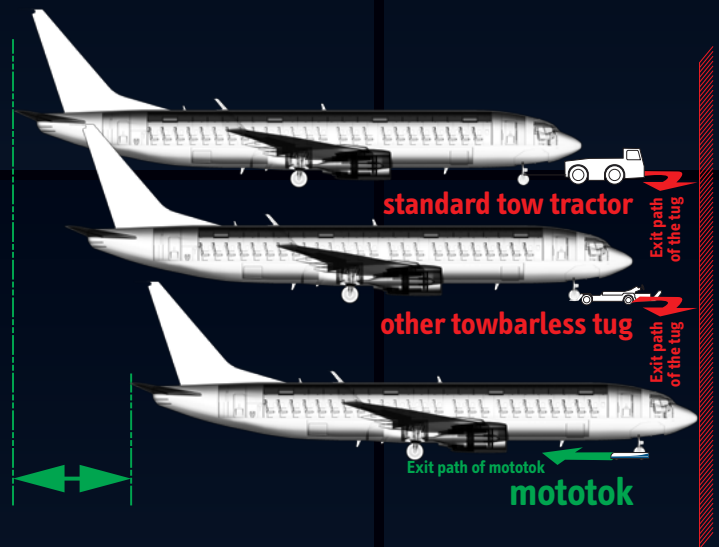

Typically situation in a hangar – managed with a conventional tow tractor. The biggest disadvantages are:

- ⊖ All aircraft faces to the hangars gate because you have to consider the exit path of the tow tractor. Parking directly in a hangars corner is impossible.
- ⊖ The distance between the aircraft has to be acceptably big.

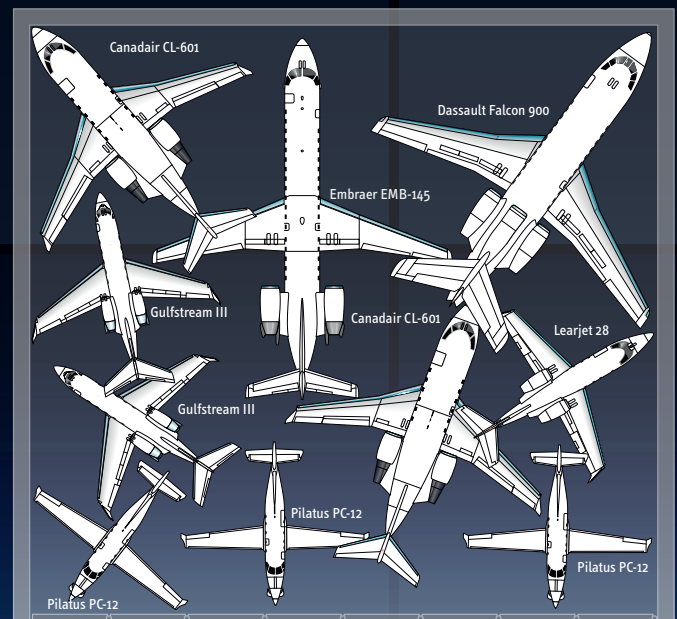

Same hangar with electric wireless remote controlled Mototok aircraft tug:

- ⊕ Park your aircraft directly towards a wall or in the hangars corner. You don't have to consider the exit path of mototok.
- ⊕ "Stack" aircraft – park your aircraft with extreme minimal distance. Maneuvering in extreme narrow situations is no problem.

You are not able to use your hangars full capacity!

Increase the capacity of your hangar up to 60% by optimizing parking space!



Increase your Pushback Efficiency significantly.



Efficiency and reliability are two important features that Mototok Pushback Tugs have to offer. Our tugs have proven this every day for more than two years in LHR T5, where BA has now performed **more than 100,000 pushbacks** with our machines.

Mototok SPACER 8600 has the NTO license for Boeing 737 incl. MAX · Airbus A 220 family · Airbus A 320 family incl. NEO Regional Jets like Embraer and Dash 8 will follow.



"Mototoks are reducing our Pushback Delays by more than 70 %."

Raoul Cooper, Senior Design Manager at BA

British Airways is showing the way: The high availability of Mototok machines at every gate ensures an enormous reduction in delays. With the capabilities of towing and pushing aircraft up to 95 tonnes Mototok SPACER 8600 is the ideal tug for your pushback operations. The SPACER 8600 comes with a NTO license for B 737 incl. MAX, A 220 and A 320 family incl. NEO. Regional Jets like Embraer and Dash 8 will follow. In combination with the outstanding pros of all Mototok vehicles like

- The low initial and maintenance costs
 - The eco-friendly electric drive
 - The one-man-operation without the need of any driving license
- you gain a powerful and flexible machine for all apron and – in addition – hangar operations.



Full electric drive



Wireless remotely controlled



Only one person needed for operation – the operator is his own wing walker



One-click-loading system



No driving license required



The operational training needs 2-4 hours



Reduce the waiting time for a pushback operator significantly



One Mototok pushback tug is able to manage up to 5 boarding bridges



Recharging time: about 3 hours



Up to 50 pushback operations with one battery charge



Very low maintenance costs



No fuel costs



The Mototok SPACER Pushback Concept for Airports.



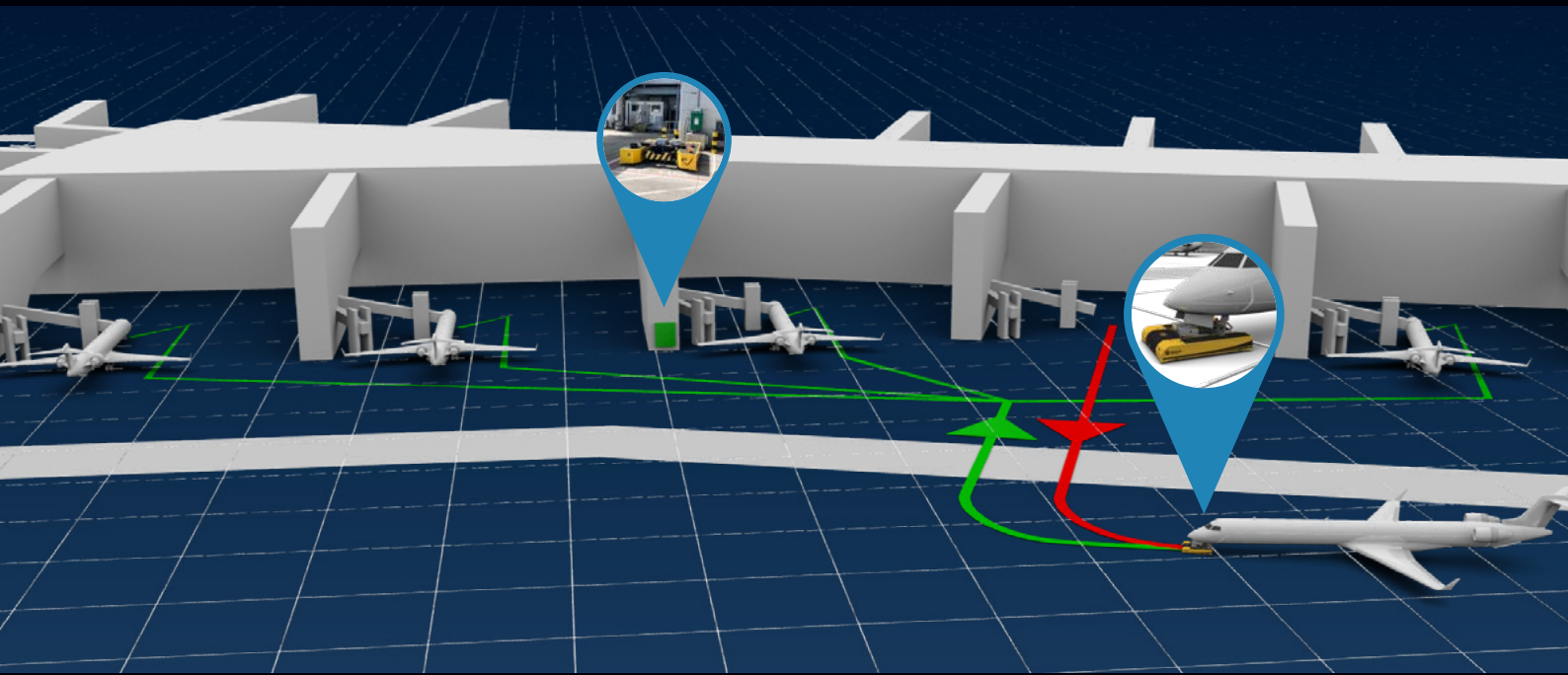

In order to increase the utilisation of a pushback tug, one Mototok SPACER is used for 3-5 boarding bridges each – depending on the departure frequency. After the pushback, the Mototok SPACER is driven to the next place of action. Due to its compact size, the Mototok SPACER is moved outside the road boundaries. Since up to 50 pushbacks are possible with one battery charge, the Mototok usually does not need to be connected to the charging station during daily operation. Charging can take place at night after closing time.

Reduce the average time of waiting for pushing back aircraft!



Every minute of waiting for the conventional pushback tug costs money.

On the contrary the access time to a Mototok pushback tug tends towards immediately. A Mototok is always at the place, where it is needed.

No governmental driving license required. Only 3 hours of training needed!



Only specialized and authorized staff is permitted to push back aircraft with a conventional pushback tug.

In contrast to this everybody of the ground handling staff has the permission to pushback the aircraft with a Mototok tug. A short driving and safety training is sufficient.

Low space requirement and small dimensions

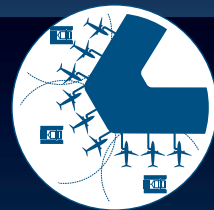

Our concept is to provide up to five boarding bridges with one electrical Mototok tug.

Mototok can be parked directly in the immediate vicinity of the gate without becoming an obstruction.



80%
TORQUE
LIMIT
REACHED

COUNTERSTEERING

Safety first: I-OPS – Intelligent Oversteering Protection System.

Achieve more safety in your daily operation: Intelligent Oversteering Protection System (I-OPS) with Auto Countersteering Function is our newest contribution to prevent damages on the nose gear whilst shunting and pushback operations. Equipped with several sensors which measures the forces and torques on the nose gear, Mototoks counter steer algorithm commences, when the torque reaches a set limit. Damages of the sensitive nose gear is hereby impossible.

The difference to conventional oversteering protection systems

I-OPS takes action actively and not only with a simple alarm – when it is too late.

How this works

The intelligent oversteering control of the Mototok prohibits an oversteering incident by intelligent torque measurement and auto counter steer. When the measured torque is reaching a critical threshold of the set torque limit, a counter steer operation will be performed immediately.

- Intuitive and easy handling
- Information for operators over the display of the Mototok and over electronic speech synthesis with the wireless headset
- Information for technicians over Mototok app with Laptop or tablet



Torque measuring point

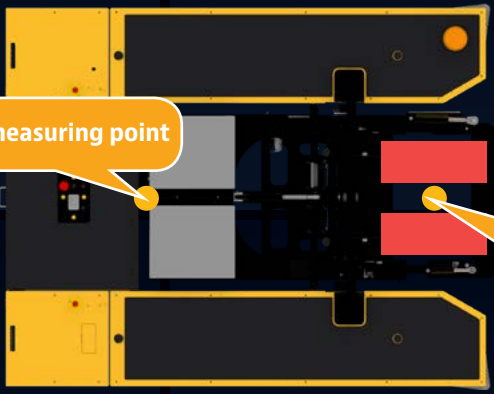

Nose wheel rotating force

The forces and torques acting on the nose gear are measured by several weighing cells. Mototok's Intelligent Oversteering Protection System (I-OPS) prevents too high torques and initiates a counter steer action whilst either pulling or pushing the aircraft.

Auto counter steer operation characteristic whilst pushing the aircraft

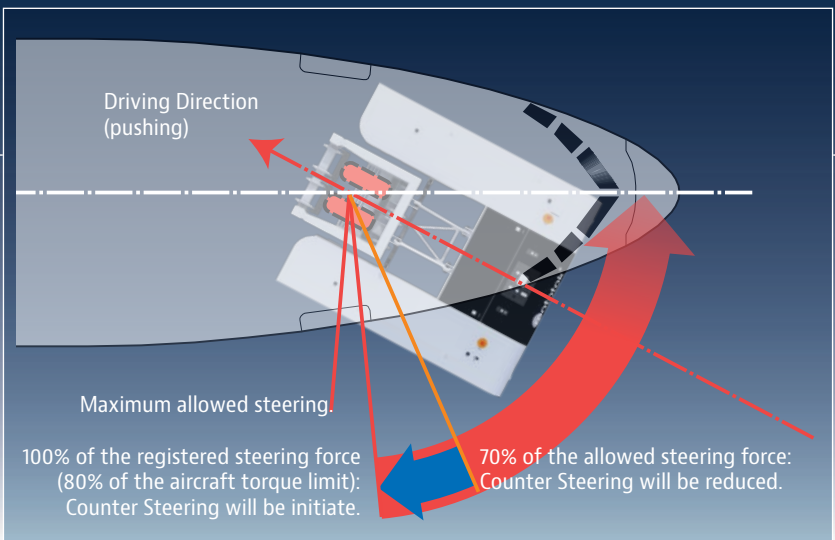
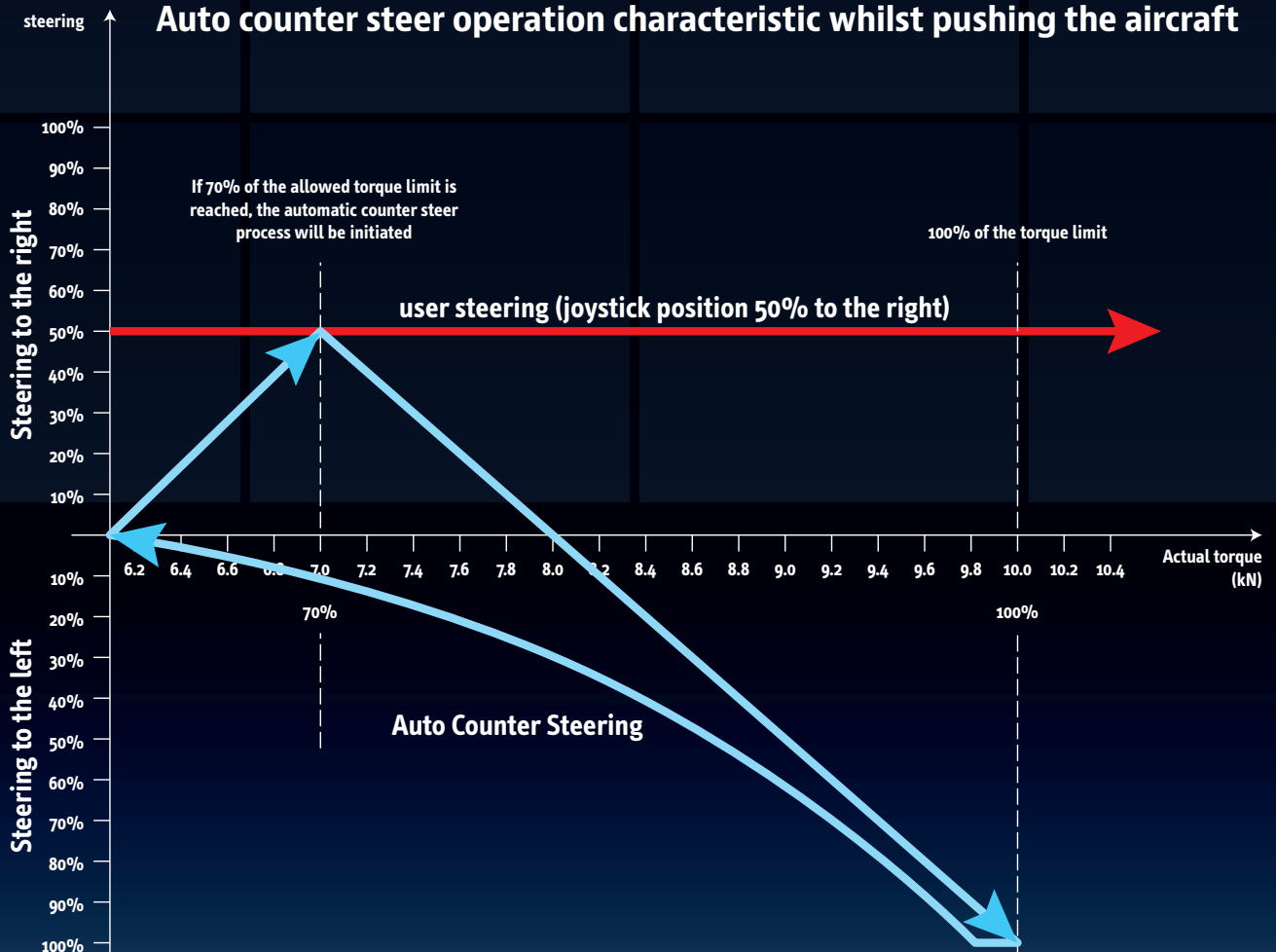



**Ground Handling goes digital.
The new soft- and
hardware features.**



Mototok comes with a central processing unit (CPU) for features and adjustments relating to

- Towing and braking forces
- Oversteering protection and counter steering
- Voice announcements
- Unit diagnostics
- Log files
- User access



The CPU can be linked with any mobile device (smartphone, tablet or laptop) via bluetooth, WLAN or USB and a standard internet browser (like Microsoft Edge, Apple Safari, Google Chrome or Mozilla Firefox). Once you are linked to the system, you are able to manage many kinds of adjustments of the Mototok.



Log in to the system

The quickest log in can be done via a RFCI-card and an appropriate card reader on the machine. According to the authorization level, the user is able to move the Mototok, check or adjust the settings or read out the log files.

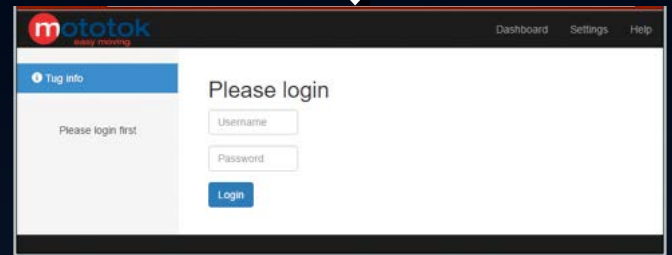

Everything in sight – from everywhere.

Always receive information about the condition and the battery status, the location and activities of each Mototok in your fleet. Connect virtually with our Mototok technicians to quickly get help with any technical problems you may have.

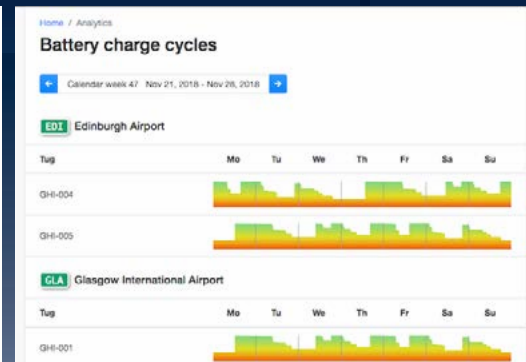
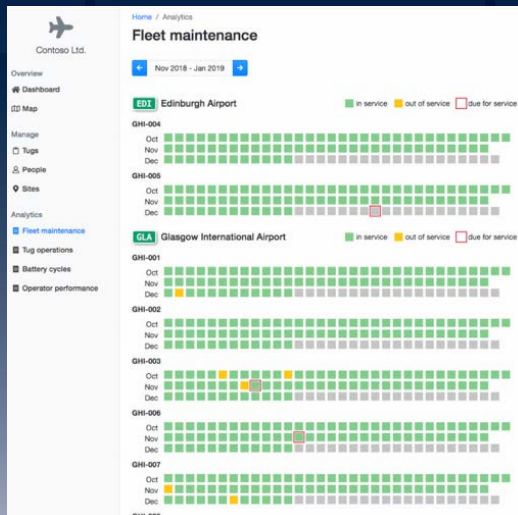
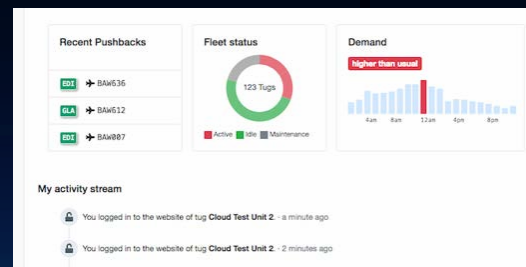



Autonomous Driving.

Moving an aircraft between four walls and other obstacles – with a Mototok an easy and safe way. But you can increase the safety once more by using our solutions for autonomous driving.



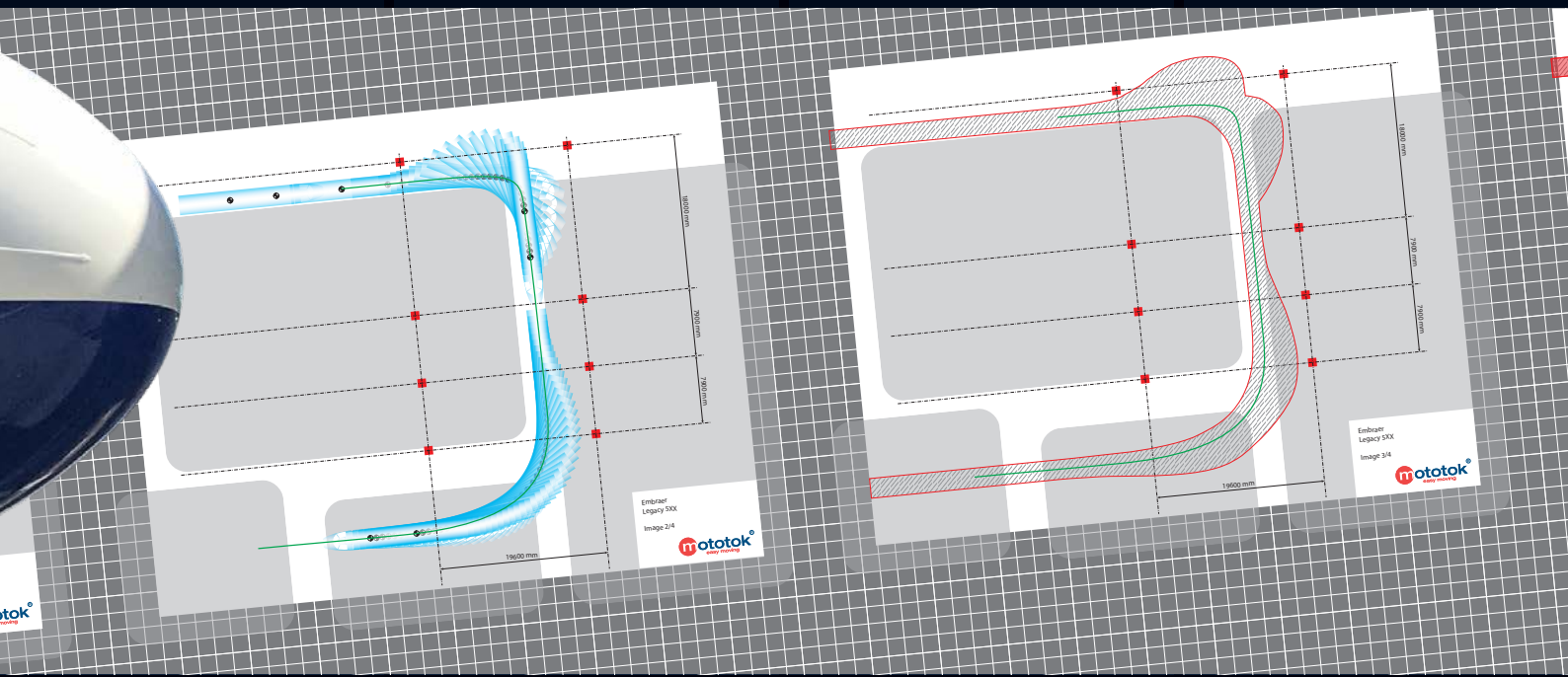

- Mototok can be controlled in different ways
- Optically by a line with barcodes for automatically brake down or speed up, stop or change the course in case of junctions
 - Inductive using induction loops
 - GPS

The advantages of using autonomous driving:

- No accidents
- No stress
- No wrong drives
- High reliability
- More precise driving
- Gentle transport for vehicle and load
- Exact route planning
- Optimized routing
- Lower personnel costs.

On production lines during aircraft manufacture, Mototok is a versatile tool that can be used with great flexibility. During assembly, Mototok automatically moves the aircraft fuselage to the individual assembly points. In very space-restricted production environments, two synchronized Mototoks may also be used.

Of course, we are at your disposal for advice and assistance in planning the optimal use in your hangar or production facility.

These and other well-known aviation companies use our automatic tracking technology in their production facilities:





Mototok SPACER 250 / SPACER 400^{*)}

- Towing capacity up to 250 t / 400 t
- Gimballed nose gear platform for compensating the tilt of the nose gear whilst turning
- Oversteering Protection and Electronic Torque Control for safely and gently turning the nose gear
- Automatic nose gear engaging function
- For aircraft with a wheel diameter of 650 – 1200 mm



WIDE BODY
NARROW BODY





HANGAR
OPTIMIZATION



MRO / FBO



	SPACER 250	SPACER 400*)
Applicable for		
Max. towing capacity	250 t / 551156 lbs	400 t / 881850 lbs
Oversteering Protection	Electronic Torque Control, optional	Electronic Torque Control, optional
Software features	available	available
Use for	<ul style="list-style-type: none"> Wide Body (e.g. A 330, A 340, A350, B 767, B 777-X, B 787) Narrow Body (e.g. A 320 Family, B 757) 	<ul style="list-style-type: none"> Wide Body (e.g. A 330, A 340, A350, B 767, B 777-X, B 787) Narrow Body (e.g. A 320 Family, B 757)

*) SPACER 400 expected to be available from 2nd half of 2020



Mototok SPACER 8600 Pushback

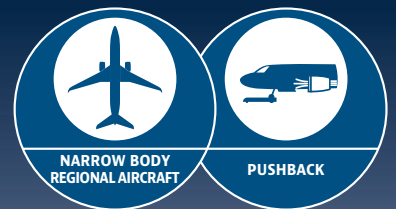

- Towing capacity up to 95 t
- Gimballed nose gear platform for compensating the tilt of the nose gear whilst turning
- Electronic torque control for safely and gently turning the nose gear
- I-OPS – Intelligent Oversteer Protection System with counter steering available
- Automatic nose gear engaging function
- For aircraft with a wheel diameter of 450 – 1200 mm
- NTO license for Boeing 737 incl. MAX and Airbus A 220, 320 family incl. NEO
Regional Jets like Embraer and Dash 8 will follow

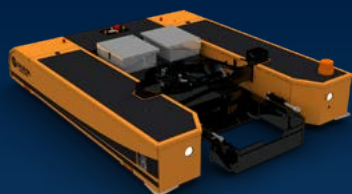

SPACER 8600 PB

applicable for



Max. towing capacity

95 t
209440 lbs

Oversteering Protection

Electronic Torque Control with counter steering, optional

Software features

available

Use for

- Narrow Body (e.g. A 320-Family, Boeing 737-Family)
- Regional Jets



Mototok SPACER 8600 MRO/FBO

- Towing capacity up to 85 t
- Gimballed nose gear platform for compensating the tilt of the nose gear whilst turning
- Electronic torque control for safely and gently turning the nose gear
- I-OPS – Intelligent Oversteer Protection System with counter steering available
- Automatic nose gear engaging function
- For aircraft with a wheel diameter of 450 – 1200 mm



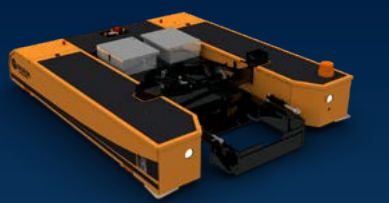

SPACER 8600 MRO

applicable for



Max. towing capacity

85 t
187300 lbs

Oversteering Protection

Electronic Torque Control with counter steering, optional

Software features

available

Use for

- Narrow Body (e.g. A 320-Family, Boeing 737-Family)
- Regional Jets



Mototok TWIN Series

The world's most compact tug for all aircraft up to 75 tonnes.

- Fully automatic nose gear engaging function
- Applicable for single or double nose wheel
- Our Flat models are also ideal for helicopters
- Hydraulic adjustment of the mouth opening depth for wheels with small diameter
- 3 different models available for aircraft up to 39, 50 or 75 t
- also as FLAT* models with extreme low height

(* Not model TWIN 3900)

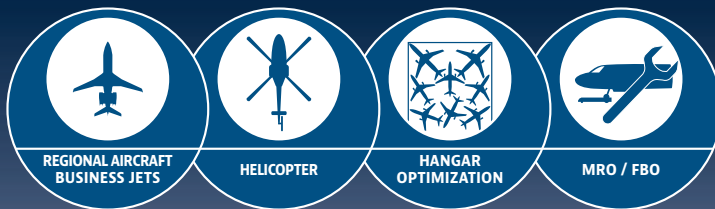



	TWIN 3900 NG	TWIN 6500 NG TWIN 6500 NG Flat	TWIN 7500 NG TWIN 7500 NG Flat
Applicable for			
Oversteering Protection	Electronic Torque Control, optional	Electronic Torque Control, optional	Electronic Torque Control, optional
Software features	available	available	available
Max. towing capacity	39 t / 85980 lbs	50 t / 110230 lbs	75 t / 110230 lbs
Use for	<ul style="list-style-type: none"> Aircraft like Bombardier Challenger - Embraer Legacy - Lear Jet - Cessna - Beechcraft - Dassault Falcon - Hawker - Pilatus Nearly all wheeled Helicopter like Sikorsky - Boeing - Eurocopter - Bell - AgustaWestland - NH 90 Military Machines like Eurofighter - Tornado - F16, F18 - Saab Gripen - Dassault Rafale - Grumman E2C Hawkeye 	<ul style="list-style-type: none"> Aircraft like Gulfstream 650 - Dassault Falcon - Global Express - ATR - Pilatus - Hawker Nearly all wheeled Helicopter like Sikorsky - Boeing - Eurocopter - Bell - AgustaWestland - NH 90 Military Machines like Eurofighter - Tornado - F16, F18 - Saab Gripen - Dassault Rafale - Grumman E2C Hawkeye 	<ul style="list-style-type: none"> Aircraft like Boeing 737 - Gulfstream 650 - Global Express - Dassault Falcon - ATR - Pilatus - Hawker Nearly all wheeled Helicopter like Sikorsky - Boeing - Eurocopter - Bell - AgustaWestland - NH 90 Military Machines like Eurofighter - Tornado - F16, F18 - Saab Gripen - Dassault Rafale - Grumman E2C Hawkeye



Mototok LB Series

The military version of the TWIN Series

- Water proofed and salt water resistant
- Applicable on aircraft carrier
- Magnetic safety system available
- Active 4-wheel-steering for a better seastate maneuvering for navy use available
- Wireless or cable connected remote control
- Red operation lights for night operations
- No problems with mounted cameras, radar or headlamps underneath the aircraft
- GPU included

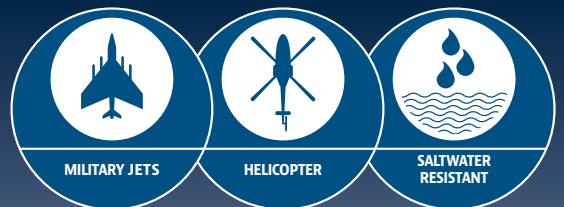



LB 7500 NG LB 7500 NG Flat	
Applicable for	
Oversteering Protection	Electronic Torque Control optional
Software features	available
Max. towing capacity	75 t 110230 lbs
Use for	<ul style="list-style-type: none"> Nearly all wheeled Helicopter like Sikorsky · Boeing · Eurocopter · Bell · AgustaWestland · NH 90 Military Machines like Eurofighter · Tornado · F16, F18 · Saab Gripen · Dassault Rafale · Dassault Mirage · Grumman E2C Hawkeye Other Aircraft like Boeing 737 · Gulfstream 650 · Dassault Falcon · ATR · Bombardier Global Express · Pilatus · Hawker



Mototok TWIN Wide

Extremely flat – for extremely wide nose wheels

- Water proofed and salt water resistant
- Applicable on aircraft carrier
- Magnetic safety system available
- Active 4-wheel-steering for a better seastate maneuvering for navy use available
- Wireless or cable connected remote control
- Red operation lights for night operations
- No problems with mounted cameras, radar or headlamps underneath the aircraft
- GPU included





TWIN WIDE	
applicable for	
Oversteering Protection	Electronic Torque Control optional
Software features	available
Max. towing capacity	85 t 187,400 lbs
Use for	<ul style="list-style-type: none"> · Military Aircraft like Lockheed C-130 Hercules · Embraer KC-390 · Airbus A400M · other military transport aircraft · Aircraft like Boeing 737 and all other bigger double wheel types



Mototok ALLIGATOR 4000

Our newest family member: the ultra flat aircraft tug. For aircraft and wheeled helicopters with extremely low ground clearance.

With a height of only 200 mm in the area of the nose wheel platform, the new Mototok Alligator is certainly one of the lowest industrial trucks in the world. With its innovative safety brackets for the nose wheel, it is also one of the safest ways to manoeuvre an aircraft or helicopter. No problems with mounted cameras, radar or headlamps underneath the aircraft



HELICOPTER

JETS

EXTREMELY FLAT

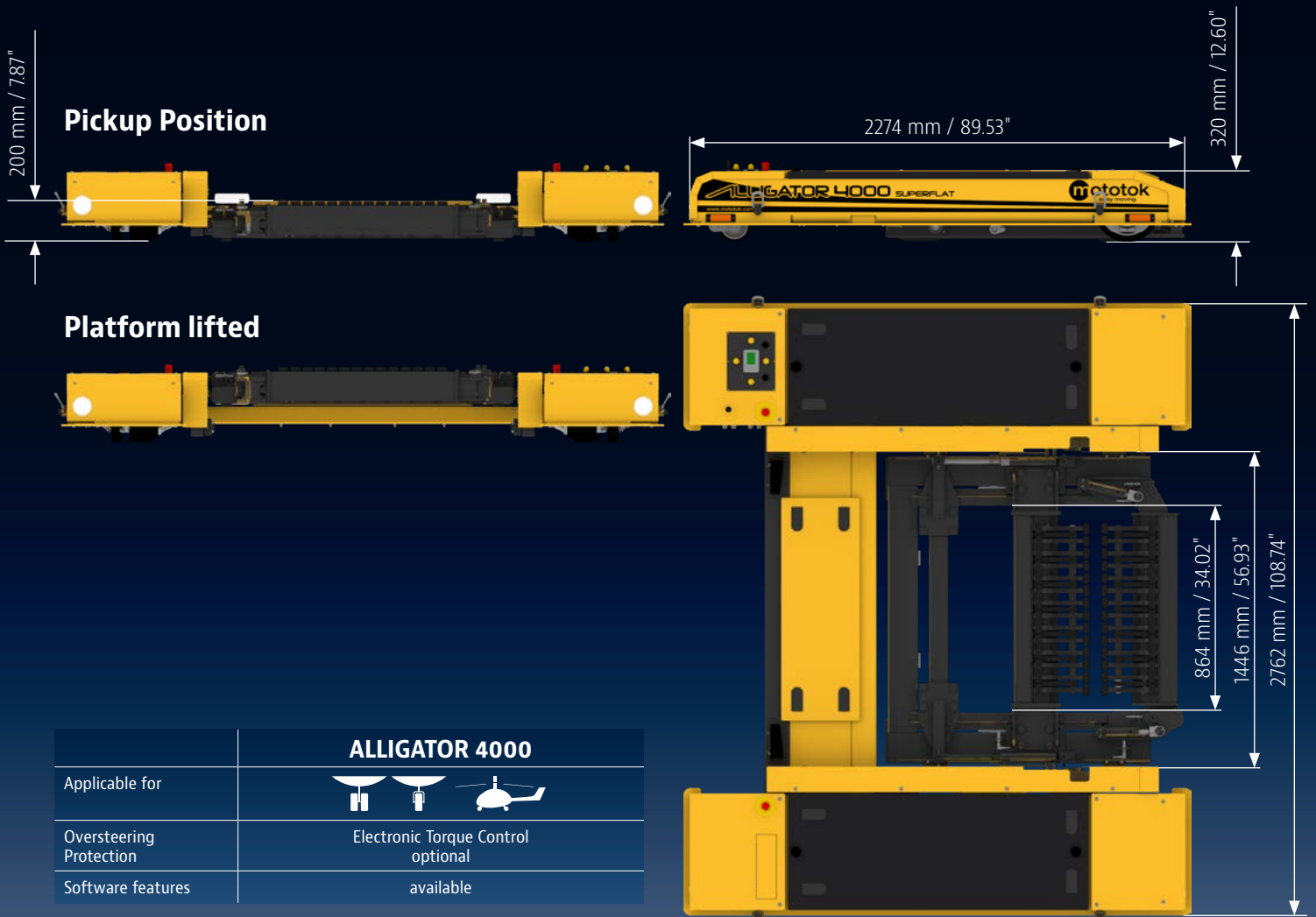



Mototok M Series

Designed for business jets with single or double nose wheel*, sporting airplanes and wheeled helicopters*

- Universal all season systems for indoor and outdoor
- Improvement of handling, flexibility and security
- Avoid of accidents, damages, pressures
- Space extraction in and around the hangar

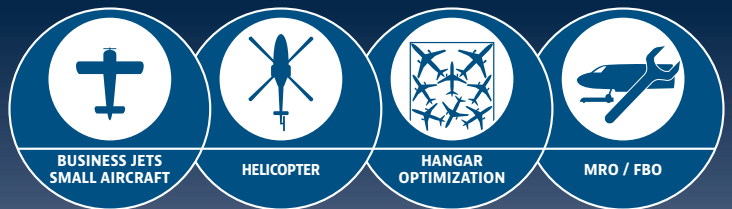

BUSINESS JETS
SMALL AIRCRAFT

HELICOPTER

HANGAR
OPTIMIZATION

MRO / FBO







- Reduction of expenses on time, personnel, equipment
- Minimization of operating, maintenance, service costs
- Hi-Tec, durability, robustness and functionality
- Optimization of environmental factors

* Model 505 for single wheel only and not for helicopter



Oversteering Protection for the M-Series

Mototok made the entry-level models of the M-Series safer. The 515 and 528 are equipped with a system to prevent oversteering and damage to the nose gear. The system interrupts the torque at predefined points. The transfer of the torque onto the nose gear will stop immediately. Beyond that, both model sounds an alarm and comes to an automatic stop.

	 M 505	 M 515	 M 528
Applicable for	 also for aircraft with nose wheel cover incl. Cirrus	 also for aircraft with nose wheel cover excl. Cirrus	 also for aircraft with nose wheel cover excl. Cirrus
Remote control	Standard industrial radio remote control	Standard industrial radio remote control	Advanced industrial radio remote control
Oversteering Protection	-	<u>Sheer pin control</u>	<u>Sheer pin with auto shut-off and alarm</u>
Max. towing capacity	5 t 11000 lbs	15 t 33000 lbs	28 t 61730 lbs
Includes	<ul style="list-style-type: none"> Nose gear rocker for convenient loading Direction indicator lights Emergency stop switches on device and remote control 4 load hooks for transport purposes 	<ul style="list-style-type: none"> Hydraulic platform for nose gear mounting Manual door opening by hand lever Manual hydraulic functions by lever and pump switch on the device: Platform lift/lower · Sliding table front/rear · Nose wheel securing up/down (optional) Hydraulic wheel adjustments for different wheel sizes/diameter 	<ul style="list-style-type: none"> Hydraulic wheel opening door with „one click“ - full automatic process for loading and unloading the nose gear Hydraulic wheel adjustments for different wheel sizes/diameter Hydraulic nose wheel securing LCD display and direction indicator lights LED spotlight set for working area Safety flashlights and beeper Emergency stop switches on device and remote control 4 load hooks for transport purposes
Additional equipment	<ul style="list-style-type: none"> LED Spotlight set for the working area Safety flashlights and beeper Ground power supply (GPU function) Ground power cable 	<ul style="list-style-type: none"> LED Spotlight set for illuminating the working area Safety flashlights and beeper Standard trailer coupling adaptor for multifunctional operation Ground power supply (GPU function) Ground power cable 	<ul style="list-style-type: none"> Standard trailer coupling adaptor for multifunctional operation Ground power cable

Unique in this device class!

A yellow and red helicopter is positioned on a heliGo mover. The mover is a white, rectangular platform with black mats and control panels. The helicopter's landing skids are resting on the mover. The background shows a paved area, green grass, and some industrial equipment under a cloudy sky.

heliGo

Helimo – the electrical and precise mover for all helicopters with landing skids.

The HELIMO moves every type of helicopter with skids regardless of obstacles such as cameras, radar, floats, winds and weapons mounted on the belly or skids of the helicopter. The HELIMO is universal and easily adjustable to meet the specifications of the helicopter. With HELIMO, you can pick up your helicopter in many different ways: from the outside or inside of its tubing and either from the front or the rear.



Remote control the Mototok from inside the Aircraft

These arms can be mounted at any possible position in seconds and fixes the skid safely.

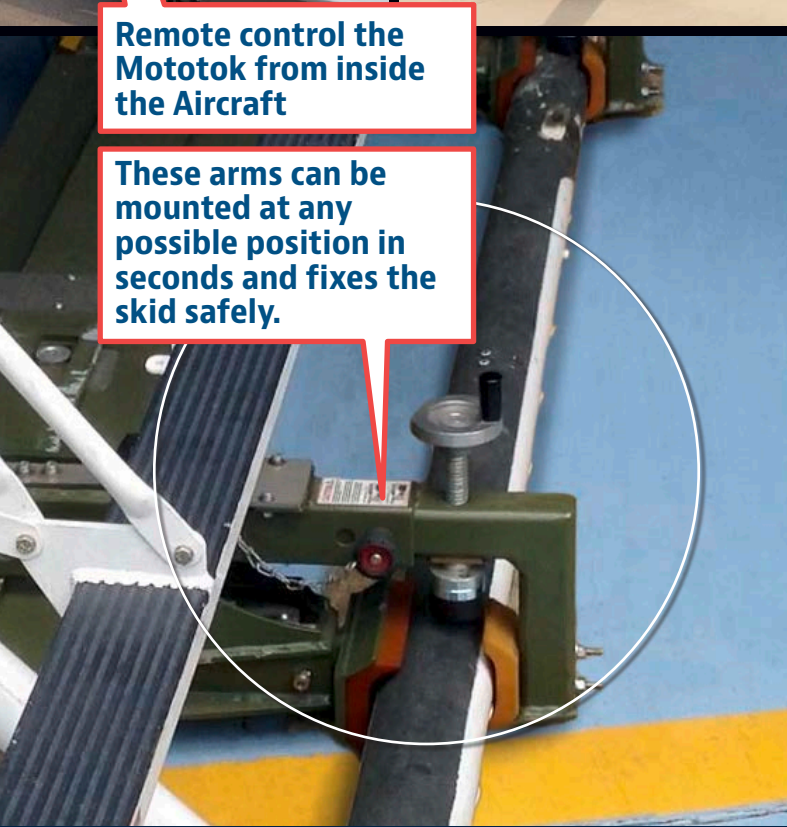

Many ways of loading your helicopter ...

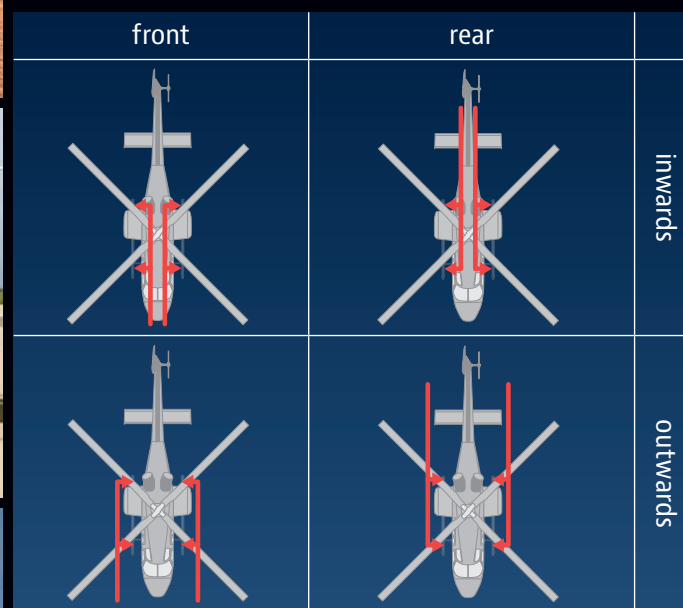

		Helimo IV	
Applicable for			
Lifting capacity		6 t 13228 lbs	
Dimensions / overall max	length	6800 mm	267.72 inch
	width	5760 mm	226.77 inch
	height	650 mm	25.59 inch
Dimensions / load area	length	6600 mm	259.84 inch
	width	2300 mm	90.55 inch
	height	250 mm	9.84 inch
Length of the extension arms		3960 mm	155.91 inch
Cantilever arms	length	300 mm	11.81 inch
	width	150 mm	5.91 inch
Ground clearance		100 mm	3.94 inch
Unladen weight		2.7 t	5952 lbs
Voltage		48 V	
Speed		5.4 km/h	
		1.5 m/s	
		3.36 mph	
Tyres		Puncture-proof tyres	
Radio remote control with safety features, waterproof, certification of conformity, worldwide safety approval, including airports (TÜV certified)			
24/28V Groundpower inclusive for engine start and updates			
Yellow flashlight inclusive			
Use for Helicopter with skids like Bell 412 · Bell 427 · Eurocopter AS 350 · Eurocopter EC 135 · Eurocopter EC 145			
Mistakes and technical alterations reserved			Date 09.2019



**Working with fire and steel:
German art of engineering.**



Our innovative built to last aircraft tractors are best equipped for daily heavy use as they consist of high-grade material, hand-picked components according to the finest engineering designs. Our products are capable of withstanding the toughest conditions when exposed to wind and salt water. Thanks to a selection of the finest materials, only limited maintenance is necessary.

Our production process corresponds and applies to all necessary demands and conditions required in the engineering industry.

2006/42/EC	Machinery Directive (MD)
2014/35/EU	Low Voltage Directive (LVD)
2014/30/EU	Electromagnetic Compatibility Directive (EMC)
2014/53/EU	Radio Equipment Directive (RED)
EN 1915-1	Aircraft ground support equipment – General requirements – Part 1: Basic safety requirements
EN 1915-2	Aircraft ground support equipment – General requirements – Part 2: Stability and strength requirements, calculation and test methods
EN 12312-7	Aircraft ground support equipment – Part 7: Aircraft movement equipment
EN ISO 12100	Safety of machinery – General principles for design – Riskassessment and risk reduction
EN 1175-1	Safety of industrial trucks – Electrical requirements – Part 1: General requirements for battery powered trucks
EN ISO 4413	Hydraulic fluid power – General rules and safety requirements for systems and their components
EN ISO 13849-1	Safety of machinery – Safety-related parts of control systems – Part 1: General principles for design
EN 60204-1	Safety of machinery – Electrical equipment of machines – Part 1: General requirements

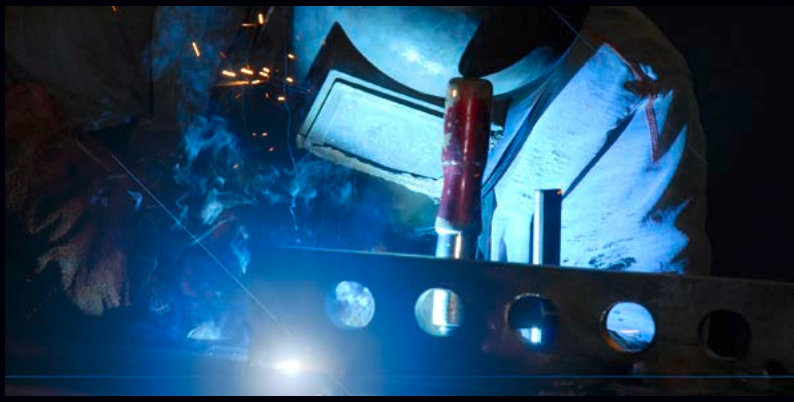

Satisfaction guaranteed – our customers

(extract)

Airports

Bern	Switzerland	Airport	Several Aircraft
Birmingham	USA	Shuttlesworth International Airport	Several Aircraft
Burbank	USA	Bob Hope Airport	Several Aircraft
Cannes	France	Mandelieu Airport	Several Aircraft and Helicopter
Chicago	USA	Chicago Executive Airport	Several Aircraft
Dallas	USA	Dallas Love Field	Several Aircraft
Denison	USA	North Texas Regional Airport	Several Aircraft
Dresden	Germany	Airport	General Aviation
Dublin	Ireland	International Airport	Several Aircraft
Glasgow	UK	International Airport	Several Aircraft
Indianapolis	USA	International Airport	Several Aircraft
Kuala Lumpur	Malaysia	Sultan Abdul Aziz Shah International Airport	Several Aircraft
London	UK	Luton Airport	Several Aircraft
Lugano	Switzerland	Airport	Several Aircraft Helicopter Agusta and others
Lyon	France	Saint Exupery Airport	Several Aircraft and Helicopter
Malaga	Spain	Airport Costa del Sol	Several Aircraft and Helicopter
McKinney	USA	National Airport	Several Aircraft
Minneapolis	USA	Saint Paul International Airport	Several Aircraft
Moskow	Russia	Domodedovo Airport	Several Aircraft and Helicopter
Orlando	USA	Sanford International Airport	Several Aircraft
Panama	Panama	Albrook „Marcos A. Gelabert“ International Airport	Several Aircraft
Philadelphia	USA	International Airport	Several Aircraft
Provo	USA	Municipal Airport	Several Aircraft
Santiago de Chile	Chile	Arturo Merino Benítez International Airport	Several Aircraft
Seattle	USA	Tacoma International Airport	Several Aircraft
Seattle	USA	King County International Airport	Several Aircraft
Sion	Switzerland	International Airport	Several Aircraft
Truckee	USA	Tahoe Airport	Several Aircraft
Tulsa	USA	International Airport	Several Aircraft
Waukegan	USA	Regional Airport	Several Aircraft
Zürich	Switzerland	International Airport	Several Aircraft and Helicopter

FBO / MRO

ACC Columbia, Hannover & Cologne	Germany	Global & others
ACI Jet Center	USA	Several Aircraft
AERO Dienst, Nuremberg	Germany	FBO
Air Service Basel	Switzerland	G5, Global Express, Boeing 737
AirMec	Angola	MRO / Military Aircraft
Alpark SA	Switzerland	Several Aircraft
Cannes	France	Several Aircraft and Helicopter
Centeravia		Several Aircraft
DUNCAN Aviation	USA	Several Aircraft
Flying Group, Antwerpen	Belgium	Several Aircraft
Glasgow	UK	Several Aircraft
Hawker Pacific Asia Pte Ltd	Singapore	Several Aircraft
Jet Alliance Vienna	Austria	Several Aircraft
Jet Legacy Center, Tulsa	USA	Several Aircraft
JetAviation, Geneva	Switzerland	Several Aircraft
London	UK	Several Aircraft
Lyon	France	Several Aircraft and Helicopter
Panaviatic Ltd	Estonia	Several Aircraft
Perth	Australia	FBO
Santiago de Chile	Chile	Several Aircraft
Sapura Aero	Malaysia	Several Aircraft
Silk Way Airlines, Baku	Azerbaijan	Several Aircraft
Starport Aviation	USA	Several Aircraft
Synergy Flight Center	USA	Several Aircraft
Tarkim Air	Turkey	General Aviation
XJET	UK	Several Aircraft
FAI Nürnberg	Germany	Several Aircraft
Executiv Jet Service	Switzerland	Several Aircraft
Alpin Sky Jets	Switzerland	Several Aircraft
Aeroground Berlind GmbH	Germany	Several Aircraft
DC Aviation GmbH	Germany	Several Aircraft
Dedeman	Rumänien	Several Aircraft
Execujet New Zealand	Neuseeland	Several Aircraft
Falcon Aviation Services	UAE	Several Aircraft
JetEx	UAE	Several Aircraft
Flying Service	Belgien	Several Aircraft
GCH Aviation	Neuseeland	Several Aircraft
Hawker Pacific Asia Pte Ltd	Australien	Several Aircraft
Jet Flight Air Services	Neuseeland	Several Aircraft
Japat AG	Switzerland	Several Aircraft
Luxembourg Air Rescue	Luxembourg	Several Aircraft
Volkswagen AG	Germany	Several Aircraft
ADAC Luftrettung	Germany	Skidded Helicopter

AIRBUS

Aero-Dienst
Your Jet - Our Job - Since 1958

airservicebasel

BOEING

MENZIES AVIATION

Alaska Airlines

BRITISH AIRWAYS

Gulfstream

Aircraft Manufacturers

Airbus S.A.S., Hamburg	Germany	Spacer
BOEING	USA	Plant in Philadelphia AGV
BOMBARDIER, Montreal	Canada	Global Express Delivery Center
Dassault Aviation	France	Twin
EMBRAER S.A.S. José dos Campos	Brasil	Embraer 195, 190, 175, 170, KC 390
Pilatus Aircraft Ltd	Switzerland	PC 12 Maintenance & Delivery
Rosvertol PLC	Russia	Helicopter Production MI-series
Sikorsky	USA	
Suchoi	Russia	
Turkish Aerospace Industries, Inc. (TAI)	Turkey	F 16 Fighter Maintenance Facility, Tiger Maintenance Facility
Xi'an Aircraft Company	China	Y 20

Corporations

Abbvie	USA	
ABP Food Group	Ireland	
Access Aviation	UK	
ACM	Chile	
ACSI Corporation	USA	
Alpine Sky Jets	Switzerland	
American Colors International	USA	
Anglo American	South Africa	Agusta AW139, G5
C & P Aviation	USA	
Caribbean Investor Group	USA	
CNH Industrial	The Netherlands	
Columbia Pacific Management	USA	
Comcast	USA	Several Aircraft
Cook Canyon Ranch	USA	
Disney	USA	
Gazprom Avia, Moscow	Russia	Falcon Jets
Harbert Aviation	USA	
Home Depot	USA	Several Aircraft
Indianapolis Colts	USA	
L-3	USA	Several Aircraft
Novartis AG (JAPAT AG), Basel	Switzerland	Global Express, EC 135
OAO Gazprom	Russia	Several Helicopter & Aircraft
Regions Financial Group	USA	
State Farm	USA	Several Aircraft
Taxxas	USA	
The Boler Company	USA	
The CocaCola Company	USA	Several Aircraft
The Duchossois Group	USA	
TLS Aviation	USA	

Government

Sultanat of Oman	Oman	Eurocopter Super Puma Fleet
------------------	------	-----------------------------

Military

Brazil Navy	Brasilien	Onboard Helicopter
CASSIDIAN Manching (EADS)	Germany	Tornado & Eurofighter
China Military	China	All kind of Aircraft, Helicopters
Columbian Air Force	Columbia	
Danish Army	Denmark	Challenger, Agusta EH 101, F 16
French Navy / Air Force	France	Rafale Fighter, SuperPuma, NH 90, EC 155, Panther
Israel Airforce	Israel	Alenia Aermacchi M-346 Master
Pakistan Military	Pakistan	HELIMO for Helicopters with skids
Peru Navy	Peru	Helicopter on the BAP Pisco
South Korea Costguard	South Korea	Onboard Helicopter
Thailand Army	Thailand	
U.S. Army National Guard	USA	M 528
US Airforce (in England)	UK	F 15
Venezuela Military	Venezuela	Helicopters with skids & with wheels

Special Forces

Federal Police	Germany	Helicopter Super Puma, EC 155
Guardia di Finanza Rome	Italy	ATR

Airlines

Aegean Airlines	Greece	
Air Nostrum, Líneas Aéreas del Mediterráneo S.A	Spain	
Alaska Airways, Seattle	USA	BOEING 737 Family
British Airways	UK	AIRBUS 320 Series
HOP!	Frankreich	
Iberia, Líneas Aéreas de España S.A.	Spain	Spacer for BOEING and Airbus
Thomson/TUI, Luton	UK	BOEING 737 Family

Pushback

Allegiant Air	USA	
ANA - All Nippon Airways	Japan	
British Airways	UK	28 Machines at Heathrow T5
Changsha Huangpi Airport	China	
DNATA	UAE	Demo
Figari-Sud Corse Airport	Frankreich	
FRAirport	Deutschland	Demo
JetBlue	USA	Demo
Rovaniemi Airport	Finnland	Demo
TCR	UK	

BOMBARDIER
the evolution of mobility

DASSAULT
AVIATION

EMBRAER

JET AVIATION





DUNCAN
AVIATION

IBERIA

PILATUS

TUI Travel PLC

Technical Data

		M-SERIES			3900 NG	6500 NG	
		M 505	M 515	M 528			
Use for		single nosewheel	single & double nosewheel, wheeled helicopter	single & double nosewheel, wheeled helicopter	single & double nosewheel, wheeled helicopter	single & double nosewheel, wheeled helicopter	
							
Maximum towing capacity ¹⁾		5 t 11023 lbs	15 t 33069 lbs	28 t 61729 lbs	39 t 85980 lbs	50 t 110231 lbs	
Maximum nosewheel weight capacity		0,6 kg 1323 lbs	1,5 t 3307 lbs	2 t 4409 lbs	4,5 t 9920 lbs	6 t 13228 lbs	
Dimensions (without antenna, grips on the surface)	width	1810 mm 71,26 inch	1810 mm 71,26 inch	1810 mm 71,26 inch	2136 mm 84,09 inch	2136 mm 84,09 inch	
		length	1810 mm 71,26 inch	1810 mm 71,26 inch	1810 mm 71,26 inch	2596 mm 102,20 inch	2596 mm 102,20 inch
	height		330 mm 12,99 inch	330 mm 12,99 inch	330 mm 12,99 inch	350 mm 13,78 inch	350 mm 13,78 inch
		Ground clearance		80 mm 3,15 inch	80 mm 3,15 inch	80 mm 3,15 inch	110 mm 4,33 inch
	Max width of the Nosewheel		160 mm 6,3 inch	500 mm 19,69 inch	500 mm 19,69 inch	665 mm 26,2 inch	665 mm 26,2 inch
	Nosewheel diameter	min.	330 mm 12,99 inch	150 mm 5,91 inch	150 mm 5,91 inch	180 mm 7,09 inch	180 mm 7,09 inch
max.		445 mm 17,52 inch	500 mm 19,69 inch	500 mm 19,69 inch	670 mm 26,38 inch	670 mm 26,38 inch	
Unladen weight		900 kg 1980 lbs	900 kg 1980 lbs	1000 kg 2200 lbs	1700 kg 3748 lbs	1700 kg 3748 lbs	
Time to load/fix aircraft (approx.)		60 sec	10 sec	10 sec	10 sec	10 sec	
Speed		5,22 km/h 1,45 m/s 3,25 mph	5,22 km/h 1,45 m/s 2 mph	5,22 km/h 1,45 m/s 2 mph	5,4 km/h 1,5 m/s 3,36 mph	5,4 km/h 1,5 m/s 3,36 mph	
	Batteries (maintenance-free, deep cycle gel batteries)		4 x 115 Ah	4 x 115 Ah	4 x 115 Ah	4 x 220 Ah	4 x 220 Ah
	Voltage		48 V	48 V	48 V	48 V	48 V
AC Microprocessor controlled electric motors		✓	✓	✓	✓	✓	
Range (depending on the workload)		2 days	2 days	2 days	3-4 days	3-4 days	
Possible terrain		Concrete, stone	Concrete, stone	Concrete, stone	Concrete, stone	Concrete, stone	
Tyres		Puncture-proof tyres	Puncture-proof tyres	Puncture-proof tyres	Puncture-proof tyres	Puncture-proof tyres	
Standard radio remote control		✓	✓	-	-	-	
Advanced radio remote control (with safety features, waterproof, certification of conformity), worldwide safety approval including airports, TÜV certified		-	-	✓	✓	✓	



Optional Equipment

Hydraulic nosewheel securing ²⁾	-	✓	✓	✓	✓
Hydraulic full hands free wheel opening doors	-	available	✓	✓	✓
Ground power cable for ground power connection 13,4V / 25,6 V (short time up to 1300 A) ³⁾	available	available	available	available	available
Driving light (LED, 10,000 hour operating life, very high beam range)	available	available	✓	✓	✓
Yellow flashlight	available	available	✓	✓	✓
Safety beeper	available	available	✓	✓	✓
Oversteering protection	-	Shear pin	Shear pin	Electronic torque control, available	Electronic torque control, available
Software features (adjusting towing and braking forces, Oversteering protection and counter steering, Voice announcements, Unit diagnostics etc.)	-	-	-	available	available
Trailer coupling adaptor for multi-functional extensions	-	available	available	available	available
Military spiral cable connection (15 m) between aggregate and control unit	-	-	available	available	available
True Ackermann active 4-wheel-steering	-	-	-	available	available
Automatic controls by ground markings (AGV)	available	available	available	available	available
Adaptations for special demands (i.e. military version / range of production)	-	available	available	available	available









Mistakes and technical alterations reserved / Date 09.2019

1) The stated towing capacity is valid for towing on normal ground conditions without any incline.

2) This prevents the nosewheel from rising and slipping out of position. The securing device is hydraulically lowered onto the nosewheel and securely locked at the push of a button.

3) In most aircraft, the generator voltage is 28.4 V. The 25.6 V on-board batteries are charged with this voltage.

With the Motokot ground power supply, the on-board voltage can be maintained and used to start the turbines. Functionality depends on the electronic of the aircraft.

TWIN-SERIES				ALLIGATOR	SPACER		
6500 NG Flat	7500 NG	7500 NG Flat	TWIN WIDE 14	4000	8600 PB	250	400
single & double nosewheel, wheeled helicopter	single & double nosewheel, wheeled helicopter	single & double nosewheel, wheeled helicopter	double nose wheel	single & double nosewheel, wheeled helicopter	double nosewheel	double nosewheel	double nosewheel
							
50 t	75 t	75 t	85 t	50 t	95 t	250 t	400 t
110231 lbs	165347 lbs	165347 lbs	187393 lbs	110231 lbs	209439 lbs	551156 lbs	551156 lbs
6 t	7.5 t	7.5 t	12 t	3.5 t	10 t	22 t	
13228 lbs	16535 lbs	16535 lbs	26456 lbs	7720 lbs	22046 lbs	48502 lbs	
2136 mm	2136 mm	2136 mm	2956 mm	2762 mm	2610 mm	3998 mm	
84.09 inch	84.09 inch	84.09 inch	116.38 inch	108.74 inch	102.76 inch	157.01 inch	
2596 mm	2596 mm	2596 mm	2596 mm	2274 mm	3305 mm	3999 mm	
102.20 inch	102.20 inch	102.20 inch	102.20 inch	89.53 inch	130.12 inch	157.44 inch	
324 mm	350 mm	324 mm	316 mm	320 mm	553 mm	879 mm	
12.76 inch	13.78 inch	12.76 inch	12.44 inch	12.60 inch	21.77 inch	34.61 inch	
85 mm	110 mm	85 mm	95 mm		81 mm	73 mm	
3.35 inch	4.33 inch	3.35 inch	3.74 inch		3.19 inch	2.87 inch	
665 mm	665 mm	665 mm	1425 mm	820 mm	851 mm	1400 mm	
26.2 inch	26.2 inch	26.2 inch	56.1 inch	32.28 inch	33.50 inch	55.12 inch	
180 mm	180 mm	180 mm	180 mm	330 mm	450 mm	650 mm	
7.09 inch	7.09 inch	7.09 inch	7.09 inch	12.99 inch	17.72 inch	25.59 inch	
670 mm	670 mm	670 mm	670 mm	480 mm	1200 mm	1200 mm	
26.38 inch	26.38 inch	26.38 inch	26.38 inch	18.90 inch	47.24 inch	47.24 inch	
1700 kg	2100 kg	2100 kg	3500 kg		5400 kg	13000 kg	
3748 lbs	4630 lbs	4630 lbs	7716 lbs		11905 lbs	28660 lbs	
10 sec	10 sec	10 sec	10 sec	10 sec	10 sec	15 sec	
5.22 km/h	3.78 km/h	3.78 km/h	3.78 km/h	3.78 km/h	5.4 km/h	10 km/h	
1.45 m/s	1.05 m/s	1.05 m/s	1.05 m/s	1.05 m/s	1.5 m/s	2.78 m/s	
3.25 mph	2.35 mph	2.35 mph	2.35 mph	2.35 mph	3.36 mph	6.21 mph	
4 x 220 Ah	4 x 220 Ah	4 x 220 Ah	4 x 220 Ah	4 x 220 Ah	Armour Plate 300 Ah with electrolyte recirculation	Armour Plate 500 Ah with electrolyte recirculation	
48 V	48 V	48 V	48 V	48 V	80 V	80 V	
✓	✓	✓	✓	✓	✓	✓	
3-4 days	3-4 days	3-4 days	3-4 days	3-4 days	3-4 days	3-4 days	
Concrete, stone	Concrete, stone	Concrete, stone	Concrete, stone	Concrete, stone	Concrete, stone	Concrete, stone	Concrete, stone
Puncture-proof tyres	Puncture-proof tyres Quarz sand particles	Puncture-proof tyres Quarz sand particles	Puncture-proof tyres Quarz sand particles	Puncture-proof tyres	Puncture-proof tyres Quarz sand particles	Puncture-proof tyres	Puncture-proof tyres
-	-	-	-	-	-	-	-
✓	✓	✓	✓	✓	✓	✓	✓
✓	✓	✓	✓	✓	✓	✓	✓
✓	✓	✓	✓	✓	✓	✓	✓
✓	✓	✓	✓	✓	✓	✓	✓
Electronic torque control, available	Electronic torque control, available	Electronic torque control, available	Electronic torque control, available		Electronic torque control with counter steering, available	Electronic torque control, available	Electronic torque control, available
available	available	available	available	available	available	available	available
available	available	available	available	available	-	-	-
available	available	available	available	available	available	available	available
available	available	available	available	available	available	-	-
available	available	available	available	available	available	available	available
available	available	available	available	available	available	available	available

Some technical data of the type SPACER 400 may change due to further development and are not fixed yet.

Mototok.

REVOLUTIONARY – FINDING INNOVATIVE SOLUTIONS OUT OF NECESSITY

Mototok was founded in 2003 by Kersten Eckert, avid aviator and creator of the Mototok, and his friend and partner Thilo Wiers-Keiser.

FUELLED BY PASSION

The invention of our aircraft tugs is a deeply personal story that began with Kersten Eckert's first solo flight at 18. His growing aggravation about a process efficient-minded Eckert considered far from ideal: Manoeuvring the aircraft while on the ground. You know the rigmarole: Waiting for the machine being laboriously transported out of the hangar, depending on having two or even three people available to watch his wings and fuselage, needing a pilot to sit inside the aircraft ready to brake if needed ...Eckert became determined on finding not only a better, but the perfect way in terms of space, speed, and effort.

CREATING THE PERFECT PRODUCT

5 years of detail-oriented developing time later, the first Mototoks hit the market: Battery-powered industrial tugs providing an all-round view around the aircraft by high technology remote control, operated by a single person.

By now, there are Mototoks available for all aircraft up to 250 tons. They are in use by international FBOs, MROs, aircraft manufacturers, special forces, airports, airlines, navy, military, industrial companies, businessmen and individuals with their own fleet.

Learn more about Mototok at www.mototok.com.



Mototok International GmbH

Hohenzollernstr. 47 · 47799 Krefeld · Germany
Phone: +49 2151 65083 82 · Fax: +49 2151 61660 99

info@mototok.com · www.mototok.com · fb.com/MototokTugs

